

GRAFFITI

WALLS

Cave Painting- 40,000 years ago!



This painting, from Bone, is of a variety a wild endemic dwarfed bovid found only in Sulawesi, which the inhabitants probably hunted

Scientists have identified some of the earliest cave paintings produced by humans.

The artworks are in a rural area on the Indonesian Island of Sulawesi. Until now, paintings this old had been confirmed in caves only in Western Europe. [Researchers tell the journal Nature](#) that the Indonesian discovery transforms ideas about how humans first developed the ability to produce art.

Australian and Indonesian scientists have dated layers of stalactite-like growths that have formed over coloured outlines of human hands. Early artists made them by carefully blowing paint around hands that were pressed tightly against the cave walls and ceilings. The oldest is at least 40,000 years old.

<http://www.bbc.com/news/science-environment-29415716>







Graffiti is MORE than just names... it
has developed into art!

Keith Haring





Banksy





Jean-Michel Basquiat "SAMO"













WWW.XENZ.DRD











TAG!

TAG!

TAG!

Start with
sticks

A R T

Outline

A R T

Erase sticks

A R T

Add interesting
shapes to the
tips (rectangles, arrows, swirls)

A R T

Shade the left side
of every stick

A R T

STEP 1. Draw a basic "W" with 4 straight lines.

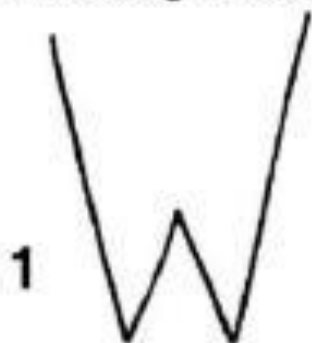

2

STEP 2. Draw rectangular bars around each line.



STEP 3. Erase the lines inside the bars.

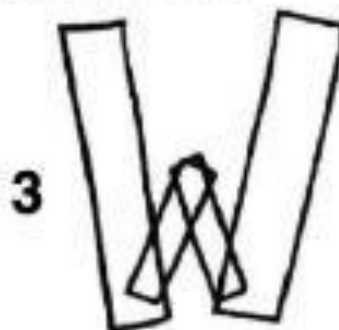

4

STEP 4. Now bend each bar in one or more places.



STEP 5. Smooth the edges on the bars to make them curvy.



STEP 6. Now move the bars to create different variations of the "W". You can lean them over to one side, make some higher or lower, shorter or longer.

STEP 7. When you find a variation that you like, draw around the outline of the "W" and erase all the guidelines. This is your finished letter.



TIP: Remember to always keep the structure of the letter the same.

HANDOUT by GraffitiDiplomacy.com

HOW TO BUILD A LETTER USING BARS

1. A graffiti letter begins with a tag letter, so loosely draw an "S".
2. Draw it again, this time squaring it off into sharp lines.
3. Draw bars around the lines any width you want, to thicken the letter, overlapping the edges.
4. Draw around the outline, erasing all the guidelines inside.
5. Smooth out the pointy edges to make it more curvy.
6. Now you can add 3-D using any method you like. See our handouts on drawing 3-D for further instructions.

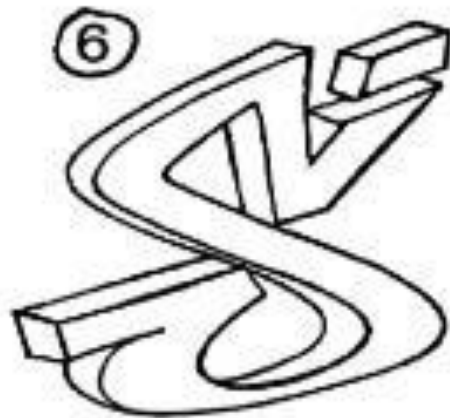
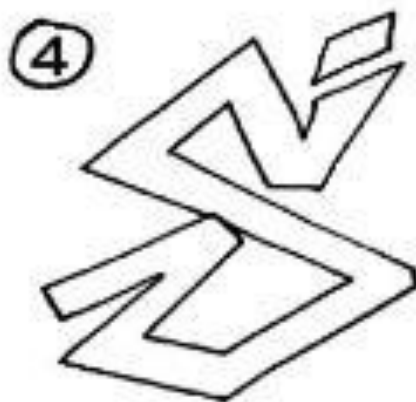
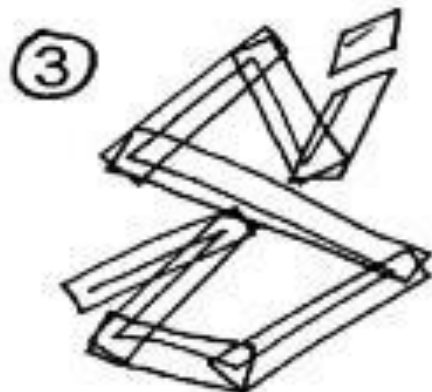
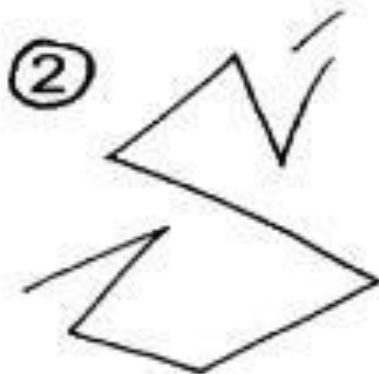

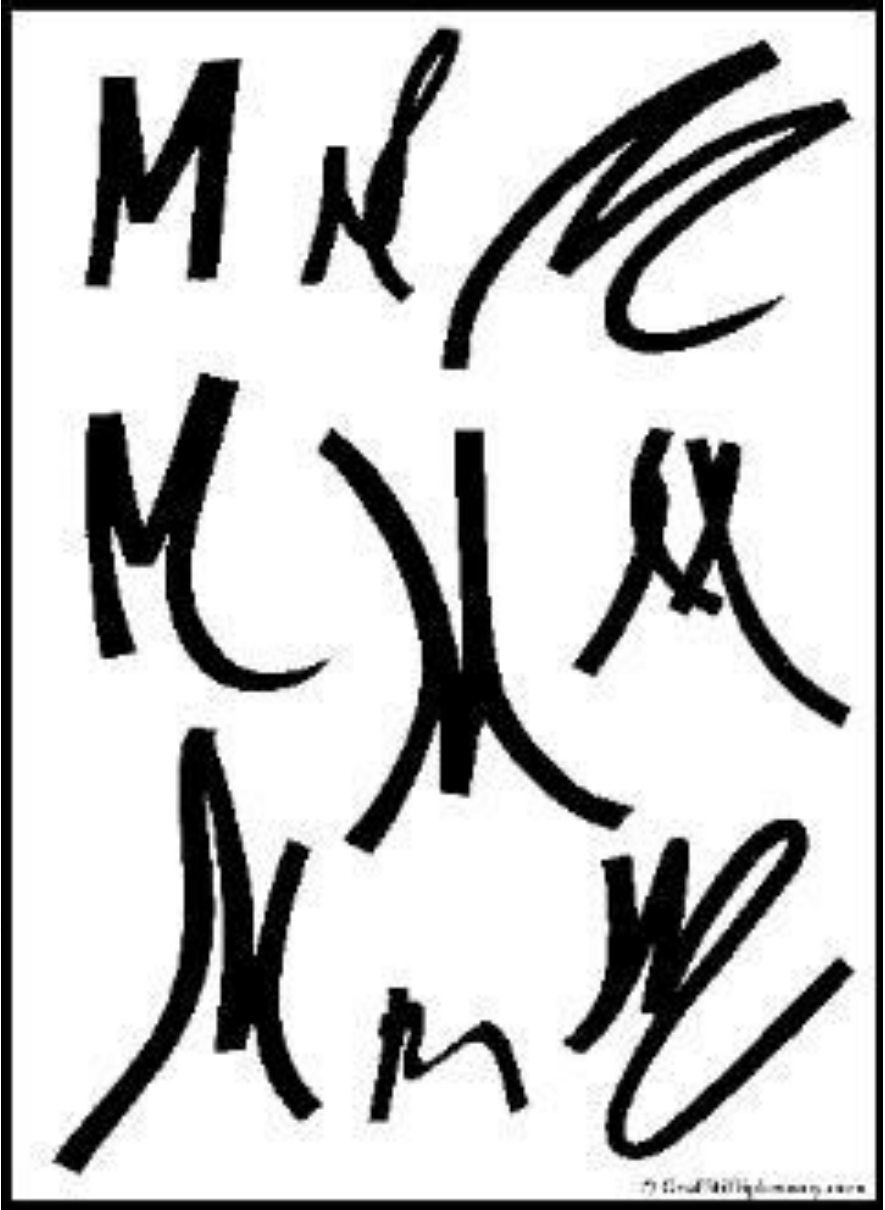
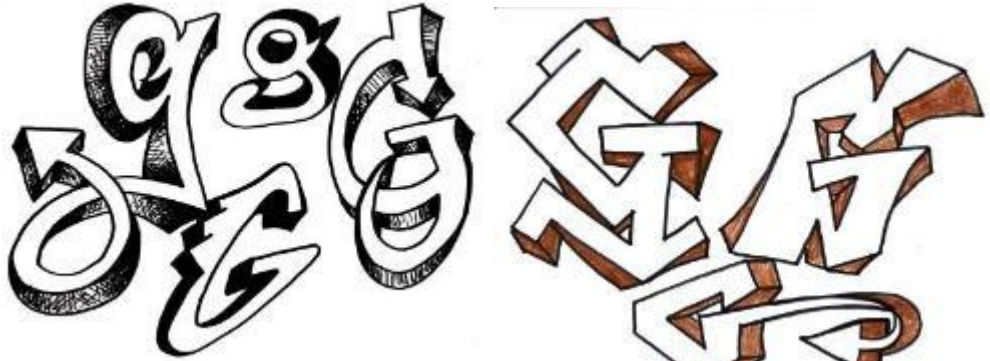



كوكبة
البرق

NADINE

NADINE

NADINE

NADINE

NADINE





